

Xgard ESU

Environmental Sampling Unit



Installation, Operation and Maintenance Instructions

M07645
Issue 5
January 2015

TABLE OF CONTENTS

1.	INTRODUCTION.....	2
2.	INSTALLATION.....	2
3.	COMISSIONING CHECKS.....	4
4.	MAINTENANCE.....	4
5.	SPARE PARTS.....	5
6.	SPECIFICATIONS.....	6
7.	APPENDIX A – ESU GENERAL ARRANGEMENT.....	7
8.	APPENDIX B – INSTALLATION OPTIONS.....	8
9.	APPENDIX C – VORTEX CONFIGURATION INSTRUCTIONS.....	9
10.	WARRANTY.....	11

1. INTRODUCTION

The ESU Environmental Sampling Unit is designed to make it easier to monitor gases such as chlorine and sulphur dioxide which, because they have a high density and are readily absorbed into many materials, are difficult to detect using conventional point detectors. The explosion proof version may be used for monitoring heavy flammable gases such as LPG. The ESU uses a sampling chamber technique in which gas is sampled using an electric fan. This is installed in the outlet from the chamber and thus draws samples through the system via pipe-work connected to the chamber.

The ESU fan and gas detector must be connected to a Crowcon Gasmaster or Vortex control panel, which will monitor the fan to ensure a sample is being drawn and display the gas level and activate alarms. Wiring diagrams are shown on page 2 of this manual.

The sampling chamber is made from high impact ABS, and houses a gas detector with its junction box on the outside. Connection points for the electrical supply to the fan are also made externally to the sampling chamber via a second junction box.

2. INSTALLATION

One or two Xgard gas detectors can be fitted to the ESU. Refer to the General Arrangement diagram on page 5 for details of how to fit the detector. A second detector (if used) is mounted at the bottom of the enclosure.

The standard arrangement is for the sampling chamber to be fitted with 3 metres of PVC pipe on either side of a T piece at the gas entry point to the chamber. It is possible to extend this to 6 metres, or to put the chamber at one end of a 12 metre length of sampling pipe. The attached chart shows that with 12 metres of straight pipe, the minimum flow rate is 0.4 metres/sec which ensures detector response in 60 seconds at most (including the T90 response time of the sensor). Any extra bends or T pieces count as 2 metres of pipe. Other options are available, for example the pipe-work can be closed at both ends with a series of small inlet holes along its length, or it can be mounted vertically with a series of sampling holes along its length but with the bottom open for immersing in liquid of varying depth. The sampling chamber should always be mounted above the surface of any liquids to avoid ingress of water.

Because of the very low pressure developed by the unit, care must be taken with siting pipes to ensure that extraneous pressure effects are eliminated, particularly in regard to wind and thermal currents with open-ended pipes.

For wet well installations Crowcon recommend that holes are drilled every 500 mm (19.7") in a vertical plane from the bottom of the open-ended pipe. To ensure that airflow is always drawn from the lowest level when the end of the pipe is submerged, the holes should be larger at the bottom, gradually reducing in diameter towards the top of the pipe. As a general rule, the lowest hole should be 6mm (1/4") in diameter, reducing by 1mm (1/25") per hole towards the top of the pipe. These figures are dependent on the total length of the pipe, and should be adjusted as necessary.

If the gas to be monitored is potentially explosive, for example heavy hydrocarbon gases which can accumulate in drains, the version certified for use in a hazardous area must be used.

It is important to note the conditions for connecting and use of the ESU to ensure compliance with the hazardous area certification.

- a. Electrical supply to the fan must be fused at the power supply at 250 mA (fuse to have a breaking a capacity of 4000A). This fuse is fitted to the fan supply PCB fitted within the fan junction box.
- b. Electrical supply to the fan junction box must be via cable suitable for hazardous areas, such as steel wire armoured type 6942X terminated via an Exd gland at the junction box.
- c. The sampling chamber must be mounted so as to be protected from receiving any direct impact.
- d. Detecting head to be cabled in accordance with instructions in the Xgard Installation, Operating and Instruction Manual.

Connect the ESU fan controller to the **Gasmaster** control panel as shown. The Gasmaster input channel 'Type' should be configured as 'ESU'. Alarm levels for the ESU input channel should be set to:

Alarm 1 On threshold (fan stalled):	10 (rising alarm, non-latching)
Alarm 1 Off threshold:	9.5
Alarm 2 threshold (fan open-circuit):	5 (falling alarm, non-latching)

Refer to the Gasmaster Installation, Operation and Maintenance Manual for more details on how to configure the input channel.

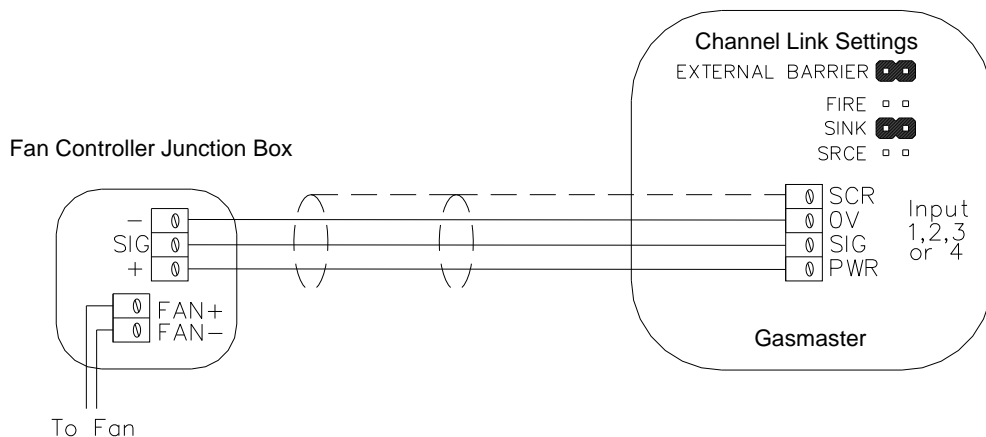

Connect the ESU fan controller to the **Vortex** control panel as shown. Refer to the Appendix C of this manual for details on how to configure the input channel.

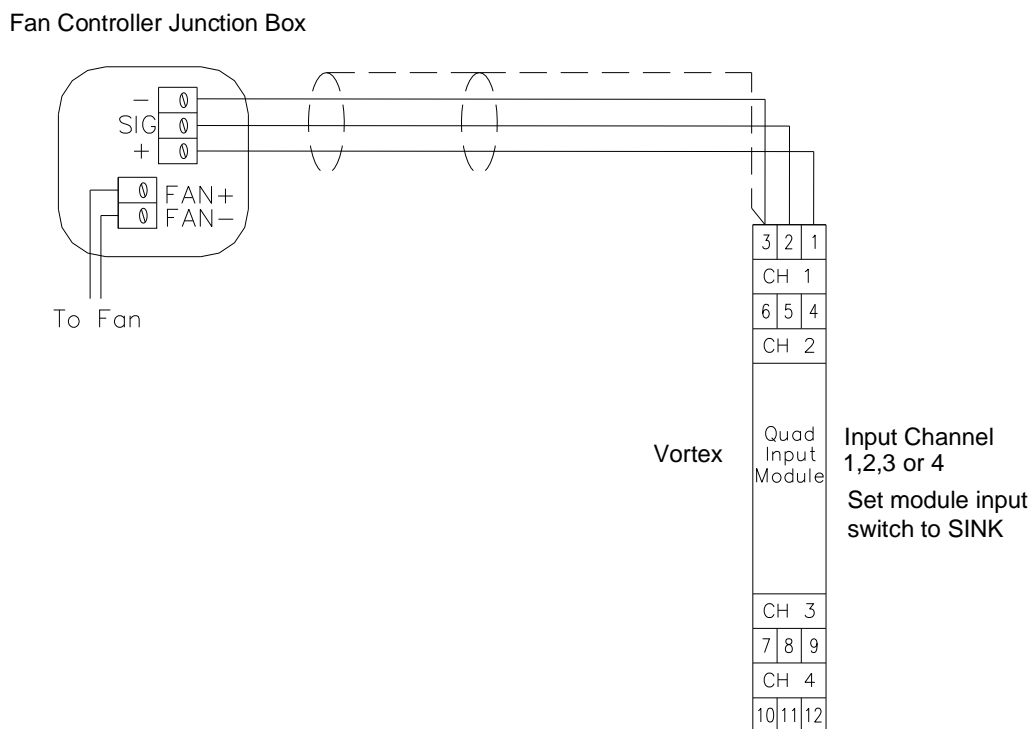

3. COMMISSIONING CHECKS

The gas detector(s) should be zeroed and calibrated in accordance with their installation instructions provided.

After installation it is recommended that a flow check is carried out. This can be done simply by holding a strand of wool or cotton by one end across each entry hole on the sample pipe and check that the strand is drawn towards the hole by the air-flow.

4. MAINTENANCE

The ESU should be inspected regularly to check that the fan or pipes are not becoming blocked, or that water has entered the sampling chamber. The gas detector(s) should be tested and calibrated by applying test gas directly to the sensor in accordance with their operating instructions.

In the unlikely event that the fan fails, the Gasmaster or Vortex system to which the ESU is connected will produce a fault signal. To identify and correct the fault follow the following:

1. Check that the fan has not become blocked and prevented from rotating, remove any obstructions.
2. Ensure there is no flammable gas present (obtain a hot work permit if necessary), un-screw the fan junction box lid and remove and test the fan supply fuse, replace if necessary.
3. If the fuse is OK and the fan is not blocked it is likely that the fan has failed. Replace the fan only with the correct part supplied by Crowcon. Alternative fans must not be used. When replacing fans on certified ESU's, it is essential that the fan cable gland is screwed securely into the fan junction box, and retained using Loctite 222 thread locking compound.

5. SPARE PARTS

- E01736 Uncertified fan assembly (safe area units only)
- S011856 'Exm' certified fan assembly (hazardous area units)
- S011857/2 Fan controller PCB
- E01307 Fuse 250mA HRC 20mm for fan
- M04873 Xgard sensor retainer adaptor
- M04874 Xgard retainer washer
- M04876 Interface gasket
- M04092 ESU cover screw

Refer to the Xgard Installation, Operating and Maintenance Instructions for gas detector spare parts information.

6. SPECIFICATIONS

Important Notice:

ESU is designed for rapid detection of significant releases of dense toxic gases such as chlorine, or a build-up of flammable vapours. The operating principle of the ESU results in a diluted gas sample being introduced to the gas detector(s), and therefore the gas level indicated by the sensor will be lower than the actual gas levels present at the release source. Ventilation procedures should always be carried out prior to entering an area where a release has occurred; and a portable gas detector should be worn by any personnel entering the area.

ESU Part Numbers	Hazardous area certified ESU: C01987 (for one sensor) C011029 (for two sensors) Non certified ESU (safe area): C011004 (for one sensor) C011031 (for two sensors)
Dimensions	397 (w) x 363 (h) x 180 (d) mm (15.3 x 10.6 x 7 ins)
Material	Polycarbonate
Fan Power	3W (Watts)
Supply Voltage (Fan)	24v DC nominal from Gasmaster
Operating Temperature	-10 to +50°C (14 to 104°F)
Approval Code (certified type only)	Fan: ATEX ^{Ex} II 2 G Ex m IIC T4 Fan junction box: ATEX ^{Ex} II 2 G Ex d IIC T6
Certificate Number	Fan: Baseefa 03 ATEX 0033X Fan junction box: Baseefa 04 ATEX 0024X
Piping	60mm Diameter PVC (2" pipe)
Maximum Pipe Length	12 Metres (36')
Weight (excluding piping)	3.5kg (7.7 lbs) excluding gas detector
Accessories	The ESU is supplied with a set of fittings comprising: Retaining nut, washer and gasket for mounting the Xgard detector(s). 2 elbows, 2 end caps, 1 T-piece, 2 reducing bushes and 4 pipe clamps. 2" pipe is available separately in 2 metre lengths.

Typical Air Flow Rates

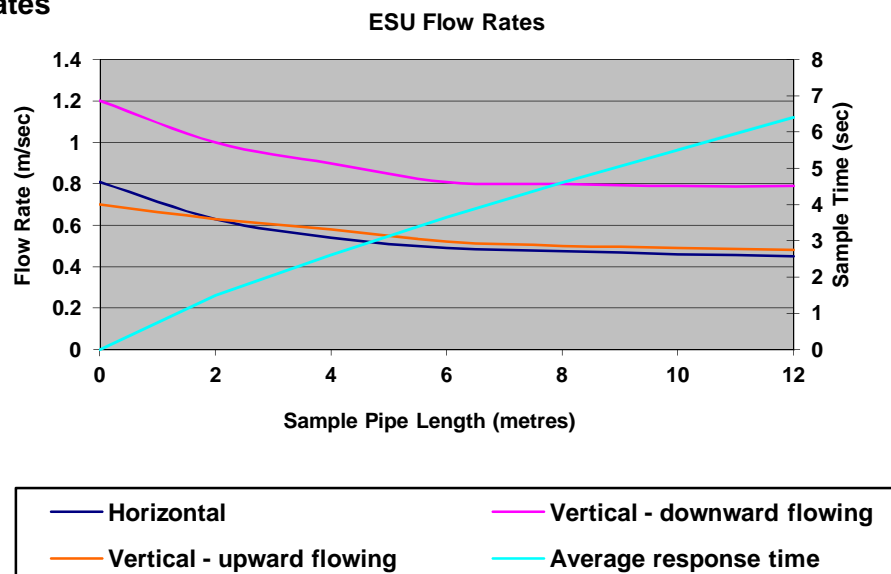

7. APPENDIX A – ESU GENERAL ARRANGEMENT

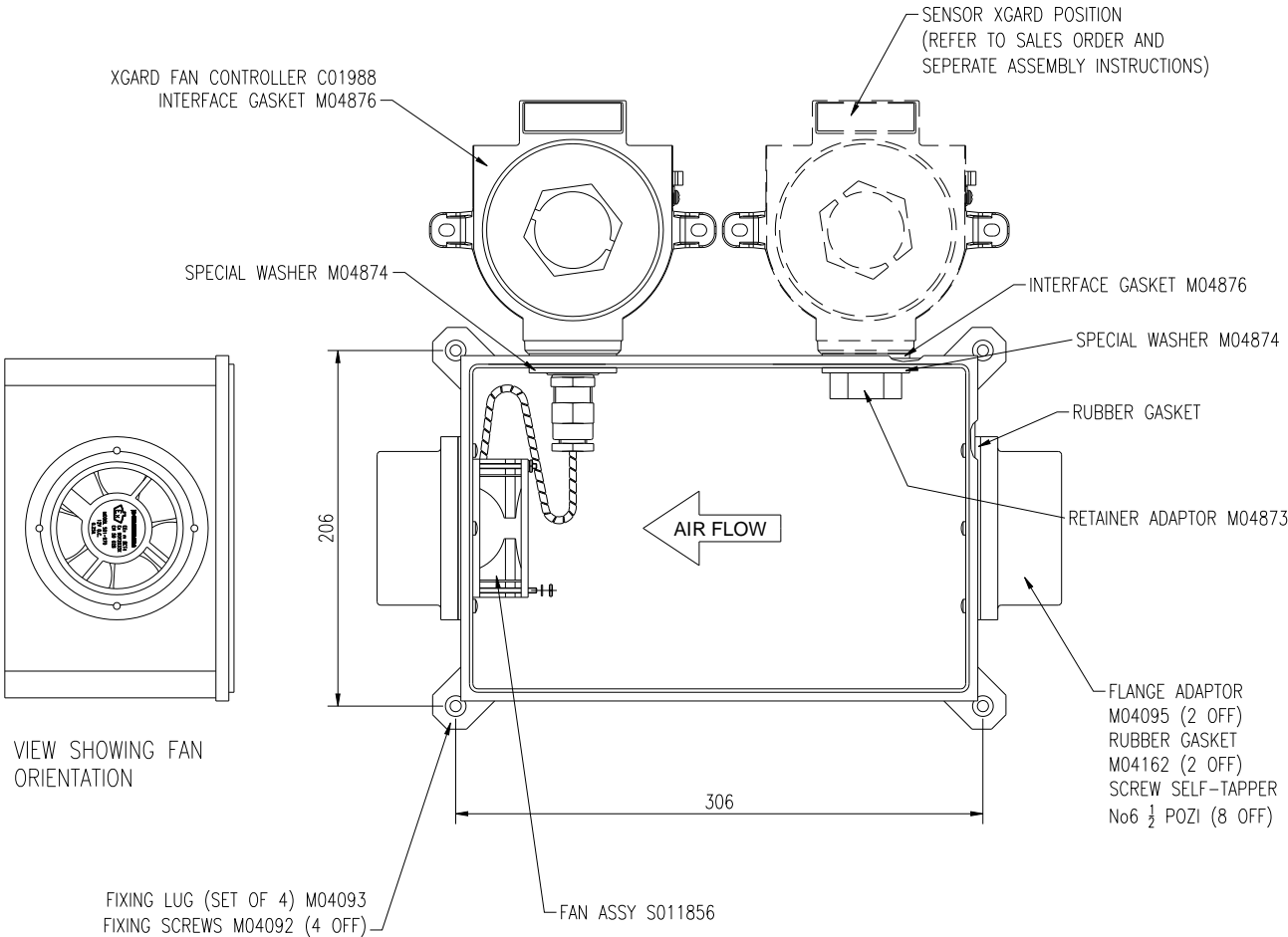

8. APPENDIX B – INSTALLATION OPTIONS

For monitoring along a horizontal surface:

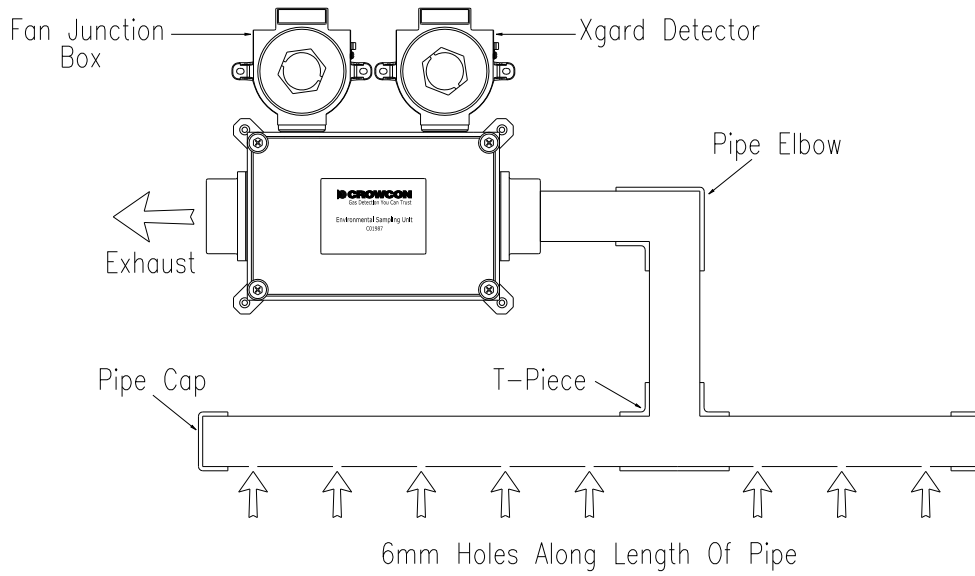

For monitoring a wet-well:

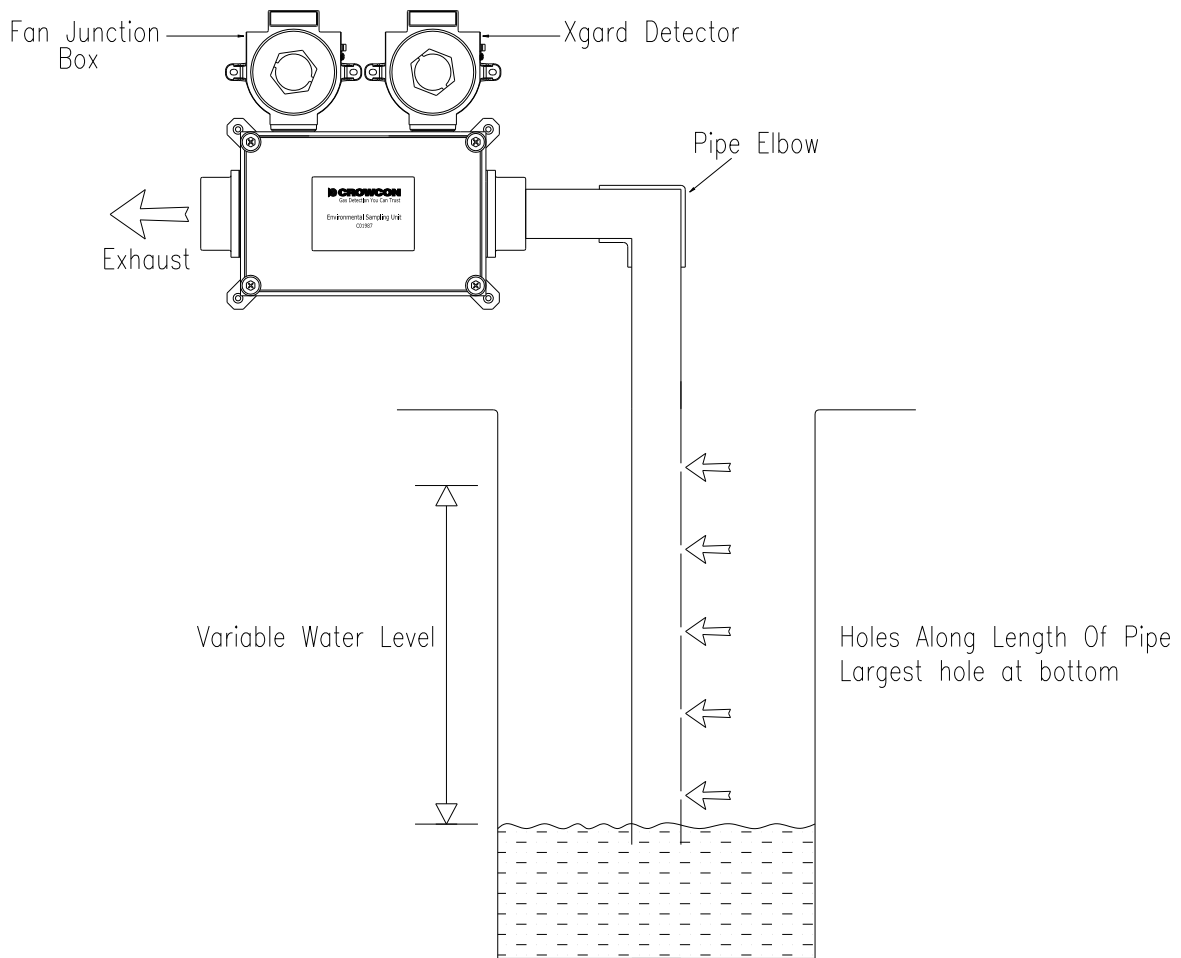

9. APPENDIX C – VORTEX CONFIGURATION INSTRUCTIONS

Once the ESU fan has been connected to the relevant Vortex input channel as described in Section 2, the Vortex control panel must be configured to provide the fan monitoring function. The following instructions describe configuration using the Vortex PC software supplied with the Vortex panel. Set all parameters as shown. The gas detector(s) fitted to the ESU should be connected as shown in the Vortex Manual.

a) Input channel configuration

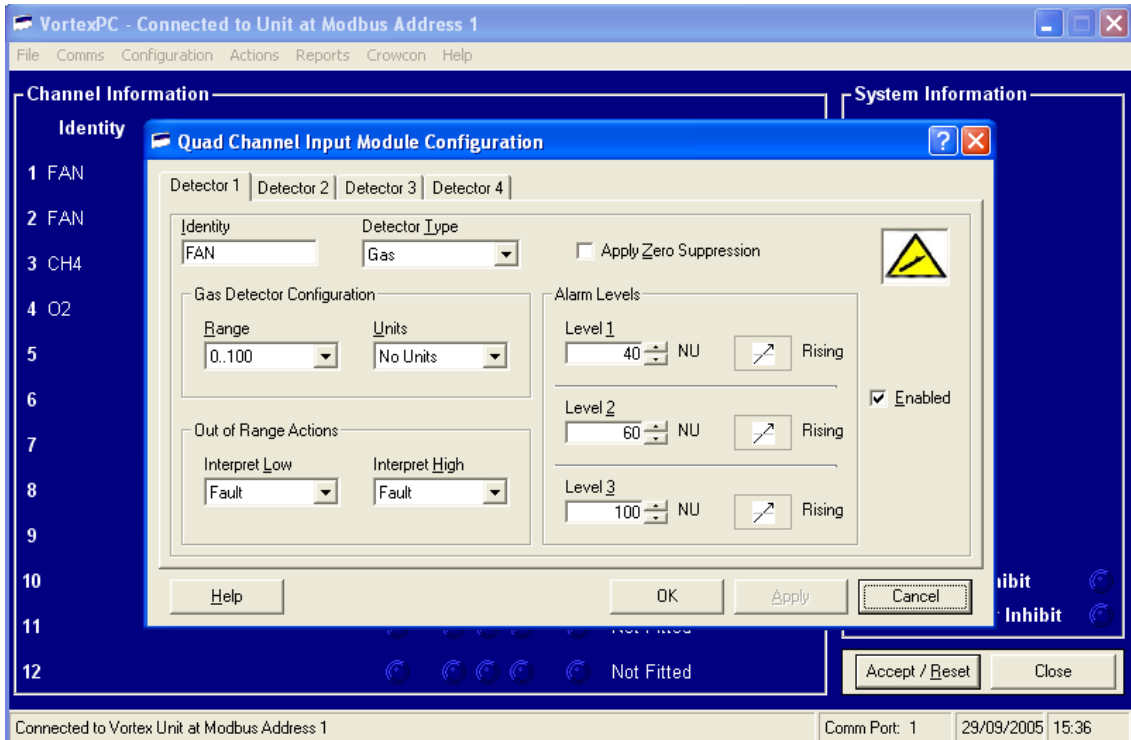

b) **Fault ('Fan Stopped or Disconnected') relay configuration:** the selected Fault relay must be set with a 3 second off delay. Level 1 and Level 2 'Fan Slow' and 'Fan Stalling' alarms can be set as latching or non-latching as required.

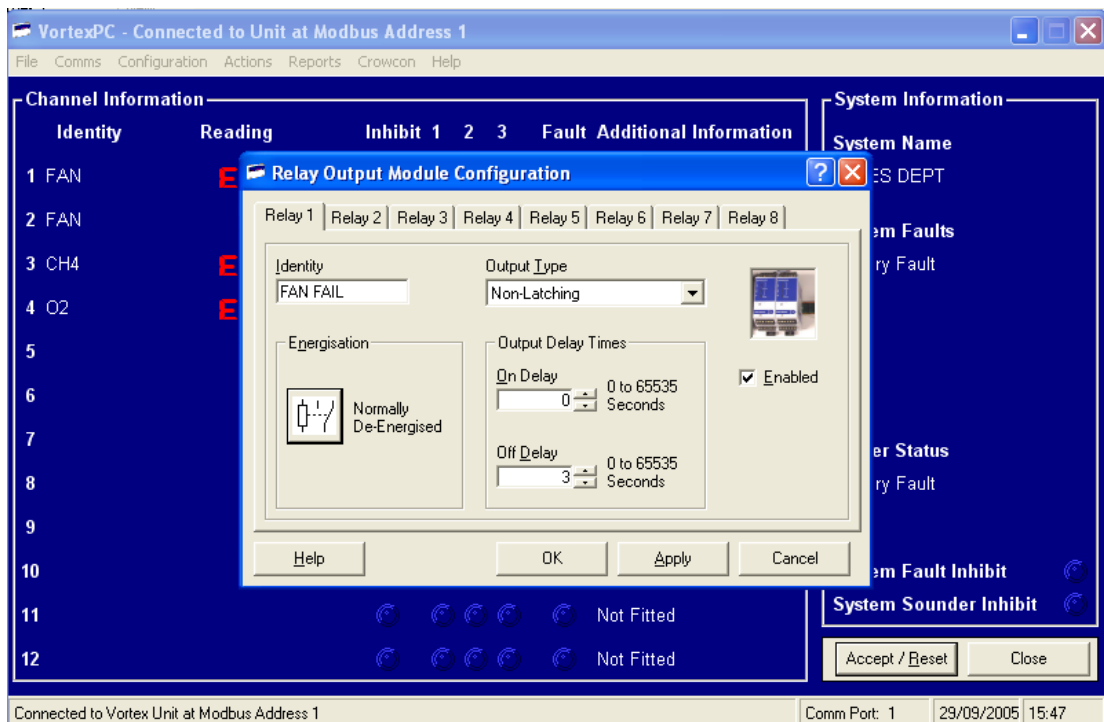

c) Fault relay logic configuration

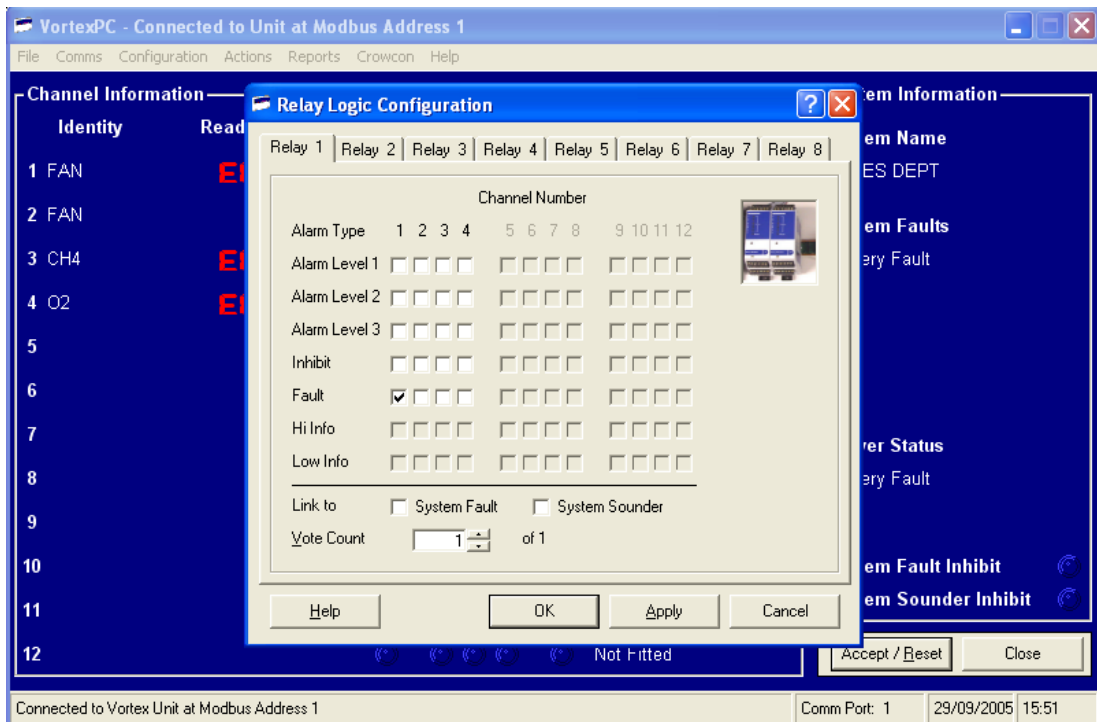

With the fan running normally the channel display should read 20-30. To test that the Vortex relay outputs operate correctly open the ESU and carefully slow the fan by resting a finger on the inner-hub, the Vortex display should rise above 40 at which point the Level 1 Fan Slow relay should activate. Apply more pressure to the hub and watch for the display to rise above 60, at which point the Level 2 Fan Stalling relay should activate. Finally, completely stop the fan and check that the display reads E006 fault, and the Fault relay activates.

Fan alarms: Alarm 1 (fan slow), Alarm 2 (fan stalling) and Fault (fan stalled), can either be assigned to individual relays or grouped to a common relay.

10. WARRANTY

Warranty Statement

This equipment leaves our works fully tested and calibrated. If within the warranty period of 1 year, the equipment is proved to be defective by reason of faulty workmanship or material, we undertake at our discretion either to repair or replace it free of charge, subject to the conditions below.

Warranty Procedure

To facilitate efficient processing of any claim, contact our customer support team on 01235 557711 with the following information:

Your contact name, phone number, fax number and email address.
Description and quantity of goods being returned, including any accessories.
Instrument serial number(s).
Reason for return.

Obtain a Returns form for identification and traceability purpose. This form may be downloaded from our website 'crowconsupport.com', along with a returns label, alternatively we can 'email' you a copy.

Instruments will not be accepted for warranty without a Crowcon Returns Number ("CRN"). It is essential that the address label is securely attached to the outer packaging of the returned goods.

Units returned to Crowcon as faulty and are subsequently found to be 'fault free' or requiring service, may be subject to a handling and carriage charge.

Warranty Disclaimer

The guarantee will be rendered invalid if the instrument is found to have been altered, modified, dismantled, or tampered with. Any service by 3rd parties **not** authorized & certified by Crowcon will invalidate the warranty on the equipment. Use of alternative manufacturer's sensors which have not been approved by Crowcon will invalidate the warranty of the product as a whole. The warranty does not cover misuse or abuse of the unit.

Repair Warranty

Product repairs within the warranty period will be free of charge for both labour and parts. Should a full service / calibration also be due, then this is agreed with the customer to be carried out at the same time as the repair and the service element will be chargeable.

Replaced parts (outside of product warranty) will usually carry a further 12 month warranty (sensor warranty exclusions are published on the Crowcon Intranet), Repairs / Service labour carries a 3 month warranty. Should a second but unrelated failure occur outside of the product warranty or parts warranty where applicable, this will be subject to separate charges.

Crowcon accept no liability for consequential or indirect loss or damage howsoever arising (including any loss or damage arising out of the use of the instrument) and all liability in respect of any third party is expressly excluded.

The warranty and guarantee does not cover the accuracy of the calibration of the unit or the cosmetic finish of the product. The unit must be maintained in accordance with the Operating and Maintenance Instructions.

Our liability in respect of defective equipment shall be limited to the obligations set out in the guarantee and any extended warranty, condition or statement, express or implied statutory or ESU Installation, Operating and Maintenance Instructions

otherwise as to the merchantable quality of our equipment or its fitness for any particular purpose is excluded except as prohibited by statute. This guarantee shall not affect a customer's statutory rights.

For warranty and technical support enquiries please contact:

Customer Support
Tel +44 (0) 1235 557711
Fax +44 (0) 1235 557722
Email: customersupport@crowcon.com



A HALMA COMPANY

© Crowcon Detection Instruments Ltd 2015

UK Office
Crowcon Detection Instruments
Ltd
172 Brook Drive,
Milton Park,
Abingdon
Oxfordshire OX14 4SD
Tel: +44 (0)1235 557700
Fax: +44 (0)1235 557749
Email: sales@crowcon.com
Website: www.crowcon.com

USA Office
Crowcon Detection
Instruments Ltd
1455 Jamike Ave, Suite 100
Erlanger
Kentucky 41018
Tel: +1 859 957 1039 or
1 800 527 6926
Fax: +1 859 957 1044
Email: salesusa@crowcon.com
Website: www.crowcon.com

European Office
Crowcon Detection Instruments Ltd
Vlambloem 129
3068JG
Rotterdam
Netherlands
Tel: +31 10 421 1232
Fax: +31 10 421 0542
Email: eu@crowcon.com
Website: www.crowcon.com

Singapore Office
Crowcon Detection
Instruments Ltd
Block 194 Pandan Loop
~06-20 Pantech Industrial Complex
Singapore 128383
Tel: +65 6745 2936
Fax: +65 6745 0467
Email: sales@crowcon.com.sg
Website: www.crowcon.com

China Office
Crowcon Detection Instruments Ltd
(Beijing)
Unit 316, Area 1, Tower B, Chuangxin
Building
12 Hongda North Road, Beijing
Economic Technological Development
Area
Beijing, China 100176
Tel: +86 10 6787 0335
Fax: +86 10 6787 4879
Email: saleschina@crowcon.cn
Website: www.crowcon.com

Crowcon reserves the right to change the design or specification of this product without notice.